

# Power Cells for Lift Trucks

Class 2 - Power Cell



## Service Features and Benefits

- Infintium's hydrogen power cell solutions are safe and clean and a **best-in-class solution** for electric lift truck power
- Hydrogen fuel cells **eliminate the need for battery rooms** or charging stations
- **Refueling takes less than three minutes** and enables a full shift of operation resulting in significant downtime savings
- The Infintium Power Cell is designed to **exceed the run-time of the batteries being replaced**



## Infintium Power Platform



### POWER CONTROL UNIT

Purpose built for precise fuel cell control with integrated multi-channel transmission for always connected fleets.



### POWER CONVERSION

Designed to scale across a wide range of vehicles sizes for optimal hydrogen power.



### FLIGHT RECORDER

Our smart design continuously records performance data to provide real-time health monitoring.



### INTELLIGENT SUITE

Suite of software modules that increase efficiency, improve reliability and extend the life of system components.

Service personnel can review data recordings of entire shifts to isolate events, faults, and execute root cause analysis to solve problems for good. Key performance indicators (KPI's) such as fuel consumption help drive improved operator performance and vehicle uptime.

To provide near real time information to Customers, Infintium's Power Cells are equipped with either wireless internet or 'cellular only' connections to Infintium's private subnet using VPN. Data is sent via encrypted protocol and uses an onboard firewall to provide secure transfers.



### Powered by Hydrogen, Infintium delivers “Power Solutions Today, for a Cleaner Tomorrow”.™

Infintium Power Cells have been certified for use by industry-leading left truck manufacturers. Rigorous testing cycles provide customers with assurance that Infintium provides a fully compatible plug-in replacement for your current lead acid battery.



### Infintium Provides Hydrogen Fuel Savings over Competitive Fuel Cells

Extensive testing at customer locations against competitive fuel cells has shown fuel efficiency improvements up to 40%. This not only lowers fuel costs by thousands of dollars every year, it also reduces refueling events, increasing driver productivity and higher asset utilization.

## Class 2 - Power Cell Specifications

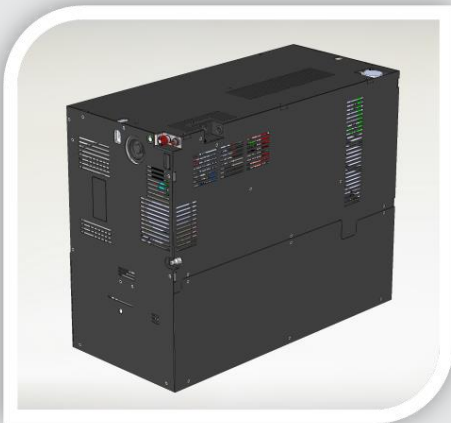

### Specifications

	PC2-H36-02	PC2-H48-02
Max Power	28kW	35kW
Rated Power Output	6.0kW	7.2kW
Nominal Voltage	36Vdc	48Vdc
Hydrogen Storage Pressure	350 bar	
Hydrogen Mass in Cylinder	0.7 kg	
Fill Time	< 2 Minutes	
Dimensions (Minimum)	38.25" X 17.75" X 30.25"	
Weight (Configurable)	2370 - 2980 lbs.	
Cooling Type	Liquid	
Operational Temp	2°C to 40°C	



### Infintium Corporate Office

3271 Brushy Creek Road  
Greenville, South Carolina 29650  
[www.infintium.com](http://www.infintium.com)

